

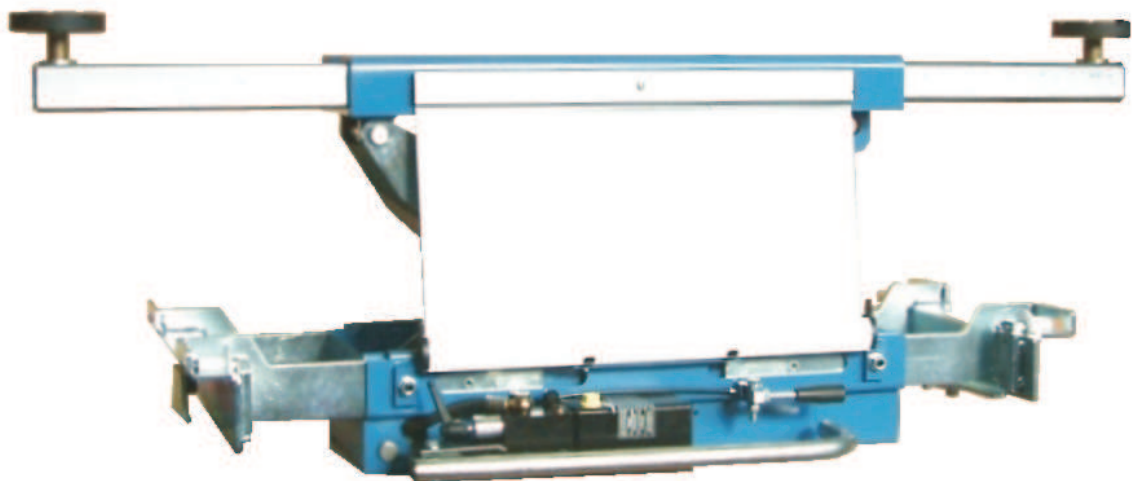

404M - 404P



I

**TRAVERSA
IDRAULICA**

GB

**HYDRAULIC
JACKING BEAM**

KIT ATTACCO STRUTTURA

KIT CONNECTING STRUCTURE

STRUKTURANSCHLUSSSATZ

KIT FIXATION STRUCTURE

KIT CONEXIÓN ESTRUCTURA

R0886 (05)

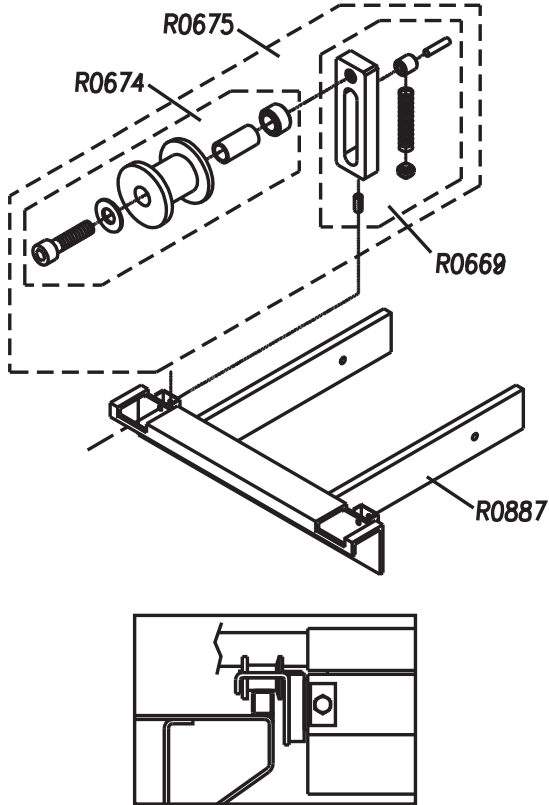

R0888 (06)

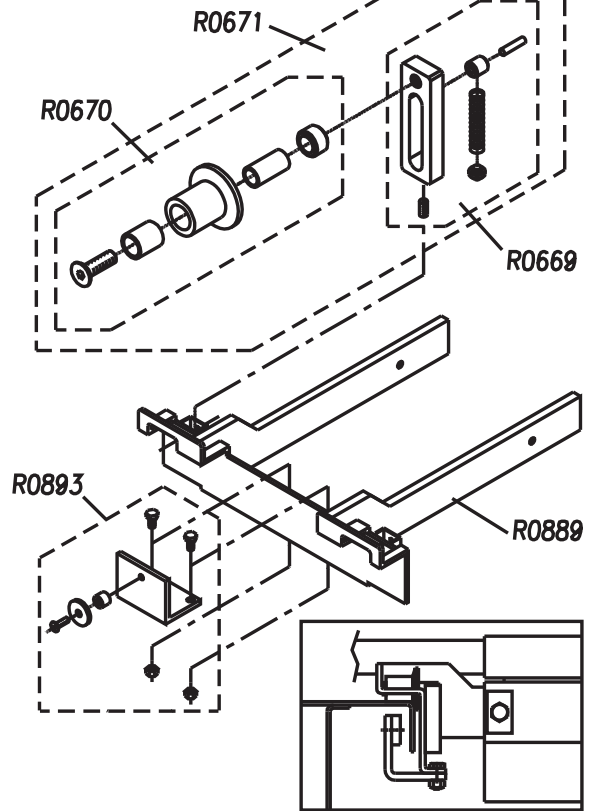

R0890 (08)

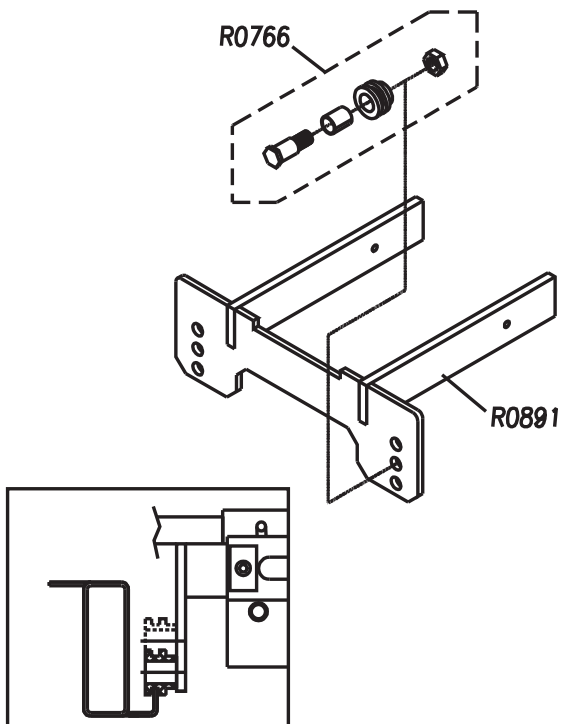

R0879

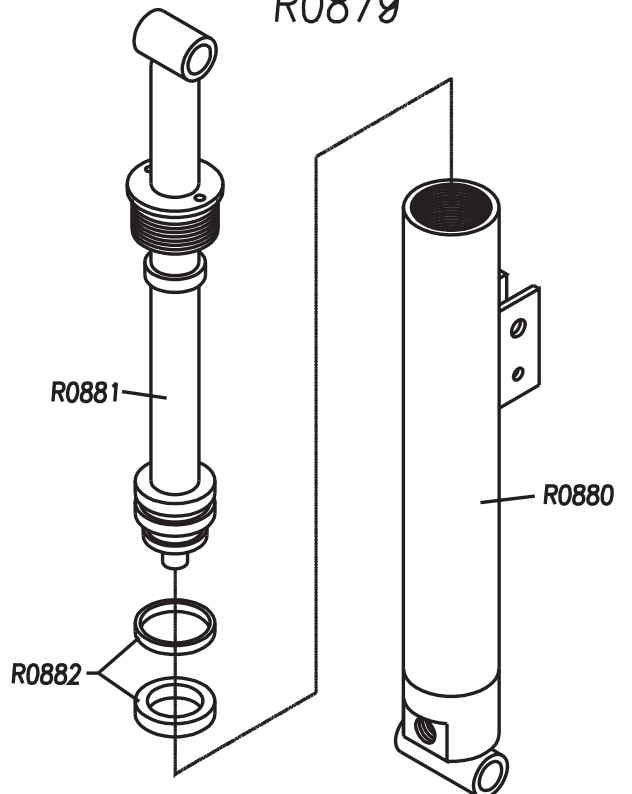

POMPA IDRAULICA

HYDRAULIC PUMP

PUMPE

POMPE

BOMBA

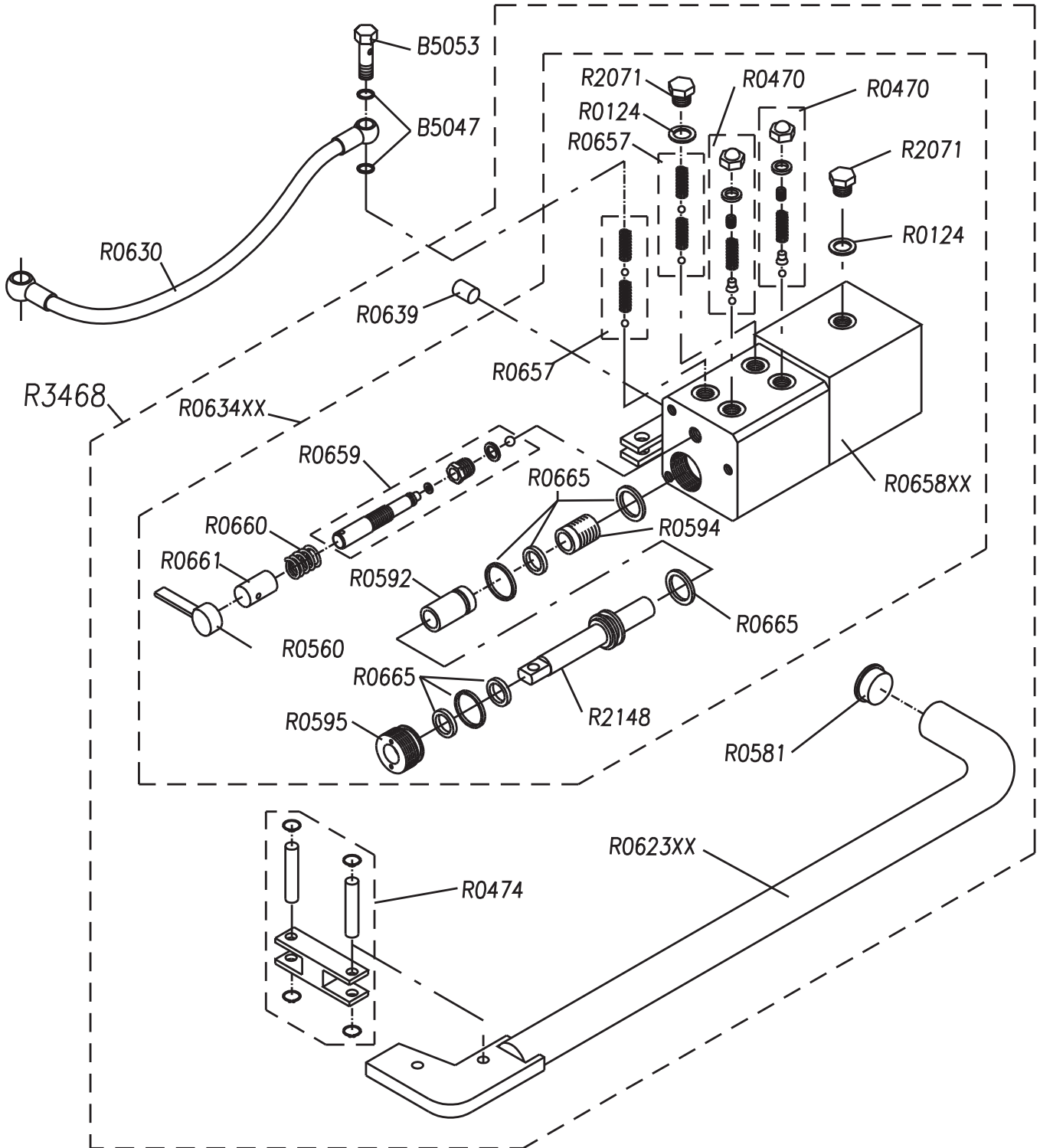

Part Code	Sugg.	Descrizione	Description	Beschreibung	Description	Denominacion
A0183		DADO M10 UNI 5588	NUT M10 UNI 5588	MUTTER M10 UNI 5588	ÉCROU M10 UNI 5588	TUERCA M10 UNI 5588
A0736		VITE TE M10X50 UNI 5737	SCREW TE M10 X 50 UNI 5737	SCHRAUBE TE M10 X 50 UNI 5737	VIS TH M10 X 50 UNI 5737	TORNILLO
B0061		ANELLO A26 UNI 7433	RING A26 UNI 7433	RING A26 UNI 7433	JONC A26 UNI 7433	ANILLO A 26 UNI 7433
B1004		PIATTELLO COMPLETO 2 COLONNE	COMPLETE PLATE	KOMPLETTER KURZEN TELLER	TAMPON COMPLET	PLATILLO COMPLETO
B1005		PIATTELLO PORTA DISCO	DISK SUPPORT PLATE	PLATTEBEHALTTELLER	PLATEAU PORTE-TAMPON	PLATILLO PORTADISCO
B1006		BOCCOLA PORTA PIATTELLO	BUSH	BUECHSE	BAGUE	CASQUILLO
B1007	*	DISCO GOMMA D 122	RUBBER DISK	GUMMITELLER	DISQUE CAOUTCHOUC	DISCO GOMA
B2847		DADO BLOCK B. M10 UNI 7474	SELF-LOCKING NUT M10 UNI 7474	MUTTER M10 UNI 7474	ÉCROU FREIN M 10 UNI 7474	TUERCA AUTOBLOQUEADORA M 10 UNI 7474
B5008		RONDELLA P 21X37X3 UNI 6592	WASHER Ø21X37X3 UNI 6592	SCHEIBE Ø21X37X3 UNI 6592	RONDELLE PLATE 21X37 UNI 6592	ARANDELA 21X37 UNI 6592
B5019		PERNO AZIONAMENTO T.L.C.	COMMAND SIDE CROSS PIN	STIFT T.L.C.	GOUJON D'ACTIONNEMENT T.L.C	PERNO ACCIONAMIENTO T.L.C.
B5047		RONDELLA DI TENUTA CON GUARNIZIONE 1/4"	GASKET WITH 1/4" SEAL	DICHTUNGSUNTERLEGSCHIEBE MIT DICHTUMG 1/4"	RONDELLE D'ÉTANCHÉITÉ 1/4"	ARANDELA DE CIERRE CON GUARNICIÓN 1/4"
B5053	*	VITE FORATA 1/4	SCREW 1/4	SCHRAUBE 1/4	PALONNIER	TORNILLO CON ORIFICIO 1/4"
B5062	*	KIT VALVOLA BLOCCA CILINDRO	CYLINDER SAFETY VALVE ASSEMBLY	ZYLINDERSPERRVENTIL	CAME DE FIN DE COURSE	KIT VÁLVULA DE BLOQUEO
B5067		SEEGER E20X2 UNI 7436	RETAINING RING E20X2 UNI 7436	SEEGER-RING E20X2 UNI 7436	CIRCLIPS E20X2 UNI 7436	SEEGER E20X2 UNI 7436
B5088		DADO BLOK M8 UNI 7474	NUT M8 UNI 7474	MUTTER M8 UNI 7474	RESSORT DE RAPPEL DE TAQUET	TUERCA AUTOBLOCANTE M8 UNI 7474
C0098		VITE TE M8X20 UNI 5739	SCREW TE M8X20 UNI 5739	SCHRAUBE M8X20 UNI 5739	VIS TH M8X20 UNI 5739	TORNILLO TE M8X20 ZINCADO
C0100		RONDELLA Ø8,4X17 UNI 6592	WASHER Ø8,4X17 UNI 6592	SCHEIBE Ø8,4X17 UNI 6592	RONDELLE Ø8,4X17 UNI 6592	ARANDELA Ø8 ZINCADA
C0410		O'RING 2018	O'RING	O'RING	JOINT TORIQUE	EMPAQUE
C0557		VITE TE M4X16 UNI 5739 ZB	SCREW	SCHRAUBE	VIS	TORNILLO
C0894		RONDELLA P 25X44 UNI 6592 ZB	WASHER P 25X44 UNI 6592 ZB	SCHEIBE 25X44 UNI 6592 ZB	RONDELLE P 25X44 UNI 6592 ZB	ARANDELA P 25X44 UNI 6592 ZB
R0046		DADO MEDIO M12 UNI 5588	NUT M12	MUTTER M12	ECROU M12	TUERCA M12
R0103		ANELLO ELASTICO ESTERNO Ø10	OUTER SPRING RING Ø10	SEEGER E10 UNI 7435	ANNEAU ÉLASTIQUE EXTERNE Ø10	ANILLO ELÁSTICO EXTERNO Ø10
R0114		SFERA 1/4"	SPHERE 1/4"	KUGEL 1/4"	BILLE	ESFERA ¼"
R0124		RONDELLA RAME D 14X20X1,5	COPPER WASHER D 14X20X1,5	KUPFER-UNTERLEGSCHIEBE D 14X20X1,5	RONDELLE	ARANDELA
R0449		SEEGER E25 UNI 7436	SEEGER E25 UNI 7436	SEEGER E25 UNI 7436	CIRCLIPS E25 UNI 7436	SEEGER
R0470		KIT VALVOLA DI MASSIMA POMPA	SAFETY VALVE KIT	SET UEBERDRUCKVENTIL	ENSEMBLE VALVE DE SURPRESSION	KIT VÁLVULA DE MÁXIMA PRESIÓN BOMBA
R0474		KIT BIELLA POMPA	CONNECTING MOD KIT	SET FLANSCH	ENSEMBLE FLASQUE	KIT BIELLA BOMBA
R0560		MANIGLIA SPILLO	PIN HANDLE	NADELGRIFF	POIGNEE DESCENTE	ASA
R0581		TAPPO LEVA	LEVER PLUG	STÖPSEL	BOUCHON	TAPÓN PALANCA
R0583		TIRANTE 496	ROD	STANGE	TIRANT	TIRANTE
R0586		PERNO X MANICO 496	HANDLE PIN	STIFT	AXE	PERNO
R0587		MANOPOLA MM70 TP FIL M10 496	KNOB MM70 TP FIL M10	DREHKNOPF	POIGNÉE	REDONDA

R0592		CILINDRO POMPANTE 496	CYLINDER PUMPING ELEMENT	ZYLINDER	VÉRIN	CILINDRO
R0594		GHIERA POSTERIORE POMPANTE 496	RING NUT HEAD PUMPING ELEMENT	NUTMUTTE	BAGUE	VIROLA
R0595		GHIERA ANTERIORE POMPANTE 496	RING NUT FRONT PUMPING ELEMENT	NUTMUTTE	BAGUE	VIROLA
R0623XX		MANICOTTO POMPANTE	SQUASHED ROPE SPRING	MUFFE	MANCHON	MANGUITO
R0624		MOLLA TASTA FUNE 496R	SQUASHED ROPE SPRING	FEDER	RESSORT	MUELLA
R0628		GUAINA L=850 CAVO 1,5 496R	SHEAT L=850 CABLE 1,5	ÜBERZUG	GAINÉ	MANGUERA
R0629		TIRANTE CON CAVO D1,5 L=1000	ROD+CABLE D1,5 L=1000	STANGE	TIRANT	TIRANTE
R0630		TUBO FLESS.496R	FLEXIBLE PIPE	SCHLAUCH 496R	FLEXIBLE HAUTE	TUBO
R0634XX		POMPA MANUALE 496R	MANUAL PUMP	PUMPE	POMPE MANUELLE	BOMBA
R0635		TENDINE PROTEZIONE 496R	PROTECTION	SCHUTZROLLO 496R	RIDEAUX DE PROTECTION 496R	PROTECCIÓN 496R
R0639		DISTANZ.PULEGGIA D.50 496R	SPACER PULLEY D.50	DISTANZSTÜCK	ENTRETOISE	DISTANCIADOR
R0640		LEVA APERTURA ZEPPA 496R	LEVER OPENING WEDGE	HEBEL	LEVIER	PALANCA
R0641		ZEPPA DI SICUREZZA 496R	SECURITY WEDGE			
R0657		VALVOLA ASPIR.COMPRESSI.496/RM	SUCTION VALVE	VENTIL	SOUPAPE	VÁLVULA
R0658XX		CORPO POMPA COMPL	COMPLETE PUMP	PUMPENKÖRPER	CORPS DE POMPE	CUERPO BOMBA
R0659		VALVOLA SCAR.496/RM	DISCHARGE VALVE	VENTIL	SOUPAPE	VALVULA
R0660		MOLLA RICHIAMO VALV.SCAR.496R	RETURN SPRING FOR VALVE	FEDER	RESSORT	MUELLE RETORNO
R0661		BUSSOLA COPRIM.VALV.SCAR.496R	BUSH SPRING VALVE	SCHRAUBE	BAGUE	CASQUILLO
R0665		KIT GUARNIZ.POMPA 496RM-RP	PUMP GASKETS SET	DICHTUNGSSATZ	JEU DE JOINTS	JUEGO DE JUNTAS
R0669		KIT PIATTO SCORRIM.401.3.5.6	KIT SLIDING PLATE 401.3.5.6	GLEITPLATTENSATZ 401.3.5.6	KIT PLAQUE COULISSEMENT 401.3.5.6	KIT PLANO DESLIZAMIENTO 496.6
R0670		KIT RULLO 401.3.6	WHEEL KIT .6	KIT FESTES .6	KIT ROUE .6	KIT RODILLO 401.3.6
R0671		KIT RULLO+SUPPORTO 401.3.6	KIT ROLLER+SUPPORT 401.3.6	SATZ ROLLE + HALTERUNG 401.3.6	KIT ROUE + SUPPORT 401.3.6	KIT RODILLO + SOPORTE 401.3.6
R0674		KIT RULLO 401.5	WHEEL KIT .5	KIT FESTES .5	KIT ROUE .5	KIT RODILLO 401.5
R0675		KIT RULLO+SUPPORTO 401.5	KIT ROLLER+SUPPORT 401.5	SATZ ROLLE + HALTERUNG 401.5	KIT ROUE+ SUPPORT 401.5	KIT RODILLO + SOPORTE 401.5
R0681		GRANO M12X30 UNI 5927 ZB	DOWEL	STIFT	GRAIN	GRANO
R0683		TUBO MANDATA OLIO 401P	OIL DELIVERY HOSE	SCHLAUCH	TUYAU D'ENVOI D'HUILE	TUBO
R0766		KIT RULLO 496.8				
R0863		ASTA DI SICUREZZA 404 ZB				
R0864		RULLO SCORRIMENTO 404 ZB				
R0865		DISTANZ.404 ZB				
R0866		PERNO ASTA DI SICUREZZA 404 ZB				
R0867		LEVA INTERNA 404 ZB				
R0868		LEVA ESTERNA 404 ZB				
R0869		PROLUNGA CENTRALE 404 ZB				
R0870		PROLUNGA LATERALE 404 ZB				
R0871XX		TELAIO TRAVERSA 404				
R0872XX		TRAVERSA MOBILE 404				

R0873		PERNO UNIONE LEVE 404 ZB				
R0874		PERNO CILINDRO-TRAVERSA 404 ZB				
R0875		PERNO CILINDRO-TELAIO 404 ZB				
R0877		PERNO SUP.TRAVERSA 404 ZB				
R0878		PERNO MOBILE SUPERIORE 404 ZB				
R0879		CILINDRO COMPL.404				
R0880		CANNA CIL.X 404				
R0881		STELO CILINDRO 404				
R0882		KIT GUARNIZ.CIL.404				
R0883		PERNO CERN.ASTA X MOLLA ZEPPA				
R0884		PERNO GUIDA MOLLA ZEPPA 404 ZB				
R0885		IMPUGNATURA TRAVERSA 404 ZB				
R0886		ATTACCO STRUT.COMPL.404.5				
R0887		APPOGGIO SCORREVOLE 404.5 ZB				
R0888		ATTACCO STRUT.COMPL.404.6				
R0889		APPOGGIO SCORREVOLE 404.6 ZB				
R0890		ATTACCO STRUT.COMPL.404.8				
R0891		APPOGGIO SCORREVOLE 404.8 ZB				
R0892		PERNO ZEPPA 404 ZB	PIN WEDGE	STIFT	AXE	PERNO
R0893		KIT STAFFA GUIDA APPOGGIO.6				
R1006		DADOBK M20X1.5 UNI 7474 ZB	SELF-LOCKING NUT M20X1.5 UNI 7474 ZB	MUTTER M20X1.5 UNI 7474 ZB	ÉCROU AUTOBLOQUANT M20X1.5 UNI 7474 ZB	TUERCA BLK M20 X 1,5 UNI 7474 ZB
R2071		TAPPO TE 1/4	BLIND PLUG TE 1/4	STÖPSEL TE 1/4	BOUCHON AVEUGLE TE 1/4	TAPÓN TE 1/4
R2148		POMPANTE DE	DE PUMPING ELEMENT	STEMPEL DE	ELÉMENT POMPANT DE	MANDO DE BOMBEO
R2302		O'RING 117	O'RING	O'RING	JOINT TORIQUE	EMPAQUE
R3132		SFERA 5/16°	BALL 5/16°	KUGEL 5/16°	BILLE 5/16"	ESFERA 5/16"
R3201		SERBATOIO BIANCO POMP	TANK	BEÄHELTER	RESERVOIR	DEPÓSITO BLANCO BOMBA
R3202		COPERCHIO POMPA HP700	COVER PLATE	DECKEL	COUVERCLE POMPE HP700	TAPA
R3203		PEDALIERA POMPA HP700	FOOT PEDAL	STEUERPEDAL	PEDALE	PEDAL BOMBA HP700
R3204		SEDE VALV. RITORNO POMPA HP700	RELEASE VALVE	VENTILSITZ	SIEGE SOUPAPE DE RETOUR	SEDE VÁLVULA RETORNO BOMBA HP700
R3205		CORPO PERNO DIFFERENZ. POMPA H	RELEASE GUIDE (TORQUE TO 0+75 -LBS OILED)	DIFFERENTIALZAPFENKOERPER (DREHMOMENT 95+100 NM GESCHMIERT)	CORPS PIVOT DIFFERENTIEL	CUERPO PERNO DIFERENCIAL BOMBA H
R3206		MOLLA PERNO DIFFERENZ. POMPA H	SPRING	DIFFERENTIALZAPFENFEDER	RESSORT TIGE DIFFERENTIEL	MUELLE PERNO DIFERENCIAL BOMBA H
R3207		PERNO DIFFERENZ. POMPA HP700	RELEASE/PLUNGER	DIFFERENTIALZAPFEN	PIVOT DIFFERENTIEL	PERNO
R3208	*	MOLLA VALV. INIZIO CICLO POMPA	SPRING	VENTILFEDER	RESSORT SOUPAPE DEBUT CYCLE	MUELLE VÁLVULA INICIO CICLO BOMBA
R3209	*	PISTONE INIZIO CICLO HP700	PISTON	KOLBEN	PISTON COMMANDE DEBUT CYCLE	PISTÓN

R3210	*	PERNO COMANDO INIZIO CICLO POM	PIN	STEUERZAPFEN	PIVOT COMMANDE DEBUT CYCLE	PERNO
R3211		SEDE VALV. POMPA HP700	POPPET GUIDE	VENTILSITZ	SIEGE SOUPAPE	SEDE VÁLVULA BOMBA HP700
R3212		RONDELLA SEDE RITORNO POMPA HP	WASHER	SCHEIBEN	RONDELLE SIEGE DE RETOUR	ARANDELA
R3213		MOLLA SFERA RITORNO OLIO POMPA	SPRNG	FEDER	RESSORT ROTULE RETOUR HUILE	MUELLE ESFERA RETORNO ACEITE BOMBA
R3214		RONDELLA RAME 14X20X1 POMPA	WASHER	UNTERLEGSCHIEBE	RONDELLE CUIVRE 14X20X1	ARANDELA
R3215		RACCORDO FILTRO ASP. POMPA	FILTER ADAPTER	SAUGFILTERNIPPEL	ADAPTEUR FILTRE ASP.	RACOR FILTRO ASPIRACIÓN BOMBA
R3216		FILTRO OLIO POMPA HP700	OIL FILTER	OELFILTER	FILTRE HUILE	FILTRO ACEITE BOMBA HP700
R3217		CORPO POMPANTE POMPA HP700	CYLINDER HP700	PUMPENGEHAEUSE	CORPS CYLINDRE	CUERPO BOMBA
R3218		CORPO POMPA HP700	PUMP BODY	PUMPENKÖRPER	CORPS DE POMPE HP700	CUERPO BOMBA
R3219		FASCETTA SERRAGGIO CANNA POMPA	RETAINING COUPLING	UNTERLEGSCHIEBE	COLLIER DE SERRAGE CHEMISE VERIN	ABRAZADERA AJUSTE CAMISA BOMBA
R3220		RONDELLA RAME 18X24X1,5 POMPA	WASHER	BRONZEBUCHSE HP700	RONDELLE CUIVRE 18X24X1,5	ARANDELA
R3222		GHIERA DI GUIDA HP 700	RETAINER PISTON GUIDE HP 700	NUTMUTTER HP700	BAGUE SEEGER	VIROLA
R3223	*	POMPANTE POMPA HP700	PISTON HP 700	KOLBEN HP700	PISTON DE POMPE	MANDO DE BOMBEO
R3224	*	CANNA POMPA HP700	CYLINDER	LAUFBUCHSE	CHEMISE DE VERIN	CAMISA BOMBA HP700
R3225		MOLLA POMPANTE POMPA HP700	SPRING	KOLBENFEDER	RESSORT	MUELLE BOMBEADOR BOMBA HP700
R3226		RONDELLA FERMO MOLLA POMPA	SPRING WASHER HP 700	FEDERHALTEPLATTE HP700	RONDELLE DE SECURITE RESSORT	ARANDELA
R3227		PISTONE POMPA HP700	PISTON	KOLBEN	PISTON	PISTÓN
R3228		RONDELLA DI TENUTA POMPA HP700	WASHER SEAL	DICHTUNGSSCHIEBE	RONDELLE D'ETANCHEITE	ARANDELA
R3229		PISTONE INVERTITORE POMPA HP70	PISTON	KOLBEN	PISTON INVERSEUR	PISTÓN
R3230		BOCCOLA FERMO OR POMPA HP700	BUSHING	O-RING-HALTERUNGSBUCHSE	BAGUE D'ARRET	CASQUILLO TOPE BOMBA HP700
R3231	*	TESTATA POMPA HP700	HEED	ZYLINDERKOPF	CULASSE	CABEZAL BOMBA HP700
R3232		FLANGIA POMPA HP700	FLANGE	FLANSCH	BRIDE	BRIDA BOMBA HP700
R3233		PERNO PISTONE INVERT. POMPA	POPPET PLUNGER	KOLBENZAPFEN	PIVOT PISTON INVERSEUR	PERNO
R3234	*	GUARNIZIONE TENUTA FRONT. POMP	HEAD GASKET	DICHTUNG	JOINT D'ETANCHEITE FRONTAL	JUNTA
R3235		RACCORDO VALVOLA LIMIT. POMPA	CONNECTION	UEBERDRUCKVENTIL-HOHLKOERPER	RACCORD SOUPAPE DE LIMITATION	RACOR VÁLVULA LIMITADORA BOMBA
R3236		SPINGIMOLLA POMPA HP700	PLUG PUMP HP700	FEDERSCHIEBER	PRESSE-RESSORT	EMPUJE DE MUELLE BOMBA HP700
R3237		MOLLA VALV. LIMITATR. POMPA	SPRING	VENTILFEDER	RESSORT SOUPAPE DE LIMITATION	MUELLE VÁLVULA LIMITADORA BOMBA
R3238		OTTURATORE VALV. LIMITATR. POM	CONE	VENTILVERSCHLUSS	OBTURATEUR SOUPAPE DE LIMITATION	OBTURADOR VALV.LIMITAD. BOMBA
R3239		SEDE VALV. LIMITATR. POMPA	SEAT	VENTILSITZTELLER	SIEGE SOUPAPE DE LIMITATION	SEDE VALV. LIMITAD. BOMBA
R3240		RONDELLA RAME 8X12X1,5 POMPA A	WASHER	UNTERLEGSCHIEBE	RONDELLE CUIVRE	ARANDELA
R3241		SEDE VALV. MANDATA POMPA HP700	BALL SEAT	VENTILSITZ	SIEGE SOUPAPE DE REFOULEMENT	SEDE VALV. DISTRIBUCIÓN BOMBA
R3242		MOLLA VALV. MANDATA POMPA	SPRING	VENTILFEDER	RESSORT SOUPAPE DE REFOULEMENT	MUELLE VALV. DISTRIBUCIÓN BOMBA

R3243		RACCORDO VALV. MANDATA POMPA	CONNECTION	UEBERDRUCKVENTIL-HOHLKOERPER	RACCORD SOUPAPE DE REFOULEMENT	RACOR VALV. DISTRIBUCIÓN BOMBA
R3244		RONDELLA NYLON POMPA HP700	SPACER	UNTERLEGSSCHEIBE	RONDELLE NYLON	ARANDELA
R3245		RACCORDO ORIENTABILE POMPA	CONNECTION	ANSCHLUSSBLOCK SCHWENKBAR	RACCORD ORIENTABLE	RACOR ORIENTABLE BOMBA
R3246		ANELLO ANTIESTRUSIONE POMPA	BK-RING	RING	BAGUE ANTI-EXTRUSION	ANILLO ANTI-EXTRUSIÓN BOMBA
R3247		SPINA PEDALE POMPA HP700	PIN	DREHSTIFT F. PEDAL	TENON PEDALE	CLAVIJA PEDAL BOMBA HP700
R3248		TAPPO OLIO TCNS 1/4 POMPA	FILTER PLUG	OELINFUELLSCHRAUBE	BOUCHON HUILE	TAPÓN ACEITE TCNS ¼ BOMBA
R3249		RONDELLA FERMO MOLLA HP700	SPRING WASHER HP 700	FEDERHALTEPLATTE	RONDELLE SECURITE RESSORT	ARANDELA
R3250		PERNO POMPA HP700	PIN	ZAPFEN	GOUJON	PERNO
R3251		VALVOLA SICUREZZA POMPA HP700	SAFETY VALVE HP700	SICHERHEITSVENTIL HP700	SOUPAPE DE SECURITE HP700	VÁLVULA SEGURIDAD HP700
R3252		RACCORDO ARIA POMPA HP700	CONNECTION	LUFTANSCHLUSS	RACCORD AIR	RACOR AIRE BOMBA HP700
R3253		FILTRO ARIA POMPA HP700	AIR FILLTER	LUFTFILTER	FILTRE A AIR	FILTRO AIRE BOMBA HP700
R3254		GUIDA SFERA POMPA HP700	BALL GUIDE	KUGELSITZ	GUIDE ROTULE	GUÍA ESFERA BOMBA HP700
R3255		RONDELLA RAME 16X20X1,5 POMPA	WASHER	UNTERLEGRING	RONDELLE CUIVRE	ARANDELA
R3256		SILENZIATORE POMPA HP700	FOAM TUBE	SCHALLDAEMPFER	SILENCIEUX	SILENCIADOR BOMBA HP700
R3257		PROTEZIONE SFERA POMPA HP700	FOAM TUBE	KUGELSCHUTZ	PROTECTION ROTULE	PROTECCIÓN ESFERA BOMBA HP700
R3258		O'RING 104 1A008	O'RING	O'RING	JOINT TORIQUE	EMPAQUE
R3259		ANELLO ANTIESTRUSIONE POMPA	BK-RING	RING	BAGUE ANTI-EXTRUSION	ANILLO ANTI-EXTRUSIÓN BOMBA
R3261		ANELLO ANTIESTRUSIONE POMPA	BK-RING	RING	BAGUE ANTI-EXTRUSION	ANILLO ANTI-EXTRUSIÓN BOMBA
R3262		TAPPO PIOMBO POMPA HP700 (107)	LEADEN PLUG	BLEISTOPFEN	BOUCHON EN PLOMB	TAPÓN PLOMO BOMBA HP700 (107)
R3264		ANELLO ANTIESTRUSIONE POMPA	BK-RING	RING	BAGUE ANTI-EXTRUSION	ANILLO ANTI-EXTRUSIÓN BOMBA
R3265		RASCHIATORE G6-10-2 POMPA	WIPER D.6	ABSTREIFRING D6	RACLEUR G6-10-2	PALA G6-10-2 BOMBA
R3272	*	O'RING 114	O'RING	O'RING	JOINT TORIQUE	EMPAQUE
R3273	*	O'RING 2050	O'RING	O'RING	JOINT TORIQUE	EMPAQUE
R3274	*	O'RING 2010	O'RING	O'RING	JOINT TORIQUE	EMPAQUE
R3275	*	O'RING 2012	O'RING	O'RING	JOINT TORIQUE	EMPAQUE
R3276		GUARNIZIONE COPERCHIO SERBATOI	SEAL	TANKDECKELDICHTUNG	JOINT COUVERCLE RESERVOIR	GUARNICIÓN TAPA DEPÓSITOS
R3277		AMMORTIZZATORE POMPA HP700	SHOCK ABSORBER HP700	STOSSDAEMPFER HP700	AMORTISSEUR	AMORTIGUADOR BOMBA HP700
R3278		O'RING 3268	O'RING	O'RING	JOINT TORIQUE	EMPAQUE
R3279		GUARNIZIONE POMPANTE POMPA	"U" CUP	KOLBENDICHTUNG	JOINT PISTON	GUARNICIÓN BOMBEADOR BOMBA
R3280	*	GUARNIZIONE PISTONE ARIA POMPA	"U" CUP	LUFTKOLBENDICHTUNG	JOINT PISTON AIR	GUARNICIÓN PISTÓN AIRE BOMBA
R3281	*	GUARNIZIONE CANNA POMPA HP700	SEEL	LAUFBUCHSENDICHTUNG	JOINT	JUNTA
R3282		GUARNIZIONE	GASKET	DICHTUNG	JOINT	JUNTA
R3283		O'RING 2100	O'RING	O'RING	JOINT TORIQUE	EMPAQUE
R3284		O'RING 3200	O'RING	O'RING	JOINT TORIQUE	EMPAQUE
R3285		VITE TCEI M5X10 UNI 5931 ZB*	HEX. SOCKET HEAD SCREW M5X10 UNI 5931 ZB*	SCHRAUBE*	VIS M5X10 UNI 5931*	TORNILLO*

R3286		O'RING 3218	O'RING	O'RING	JOINT TORIQUE	EMPAQUE
R3287		O'RING 115	O'RING	O'RING	JOINT TORIQUE	EMPAQUE
R3288		SEEGER POMPA HP700	RETAINING RING	SEEGER	BAGUE SEEGER	SEEGER
R3289		VITE TSCE 90° M5X18 UNI 5933 Z	SCREW M5X18 UNI 5933 Z	SCHRAUBE	VIS TSCE 90° M5X18 UNI 5933 Z	TORNILLO
R3290		VITE TCTC M5X10 UNI 6107 ZB	SCREW M5X10 UNI 6107 ZB	SCHRAUBE	VIS TCTC M5X10 UNI 6107 ZB	TORNILLO
R3291		GRANO BLOK STEI M6X104 POMPA H	SET SCREW (NYLOCK)	GEWINDESTIFT	GRAIN BLOK STEI M6X104	GRANO
R3293		RIVETTO ACC. 1,9X3,5 UNI 7346	RIVET	SCHRAUBE	RIVET 1,9X3,5 UNI 7346	REMACHE 1,9X3,5 UNI 7346
R3295		O'RING 119	O'RING	O'RING	JOINT TORIQUE	EMPAQUE
R3296		SEEGER AV20 POMPA HP700	SEEGER AV20	SEEGER AV20	BAGUE SEEGER AV20	SEEGER
R3333		VITE (COPPIA 2,5 NM)	SCREW (TORQUE TO 25 IN-LBS)	SCHRAUBE (ANZUGSMOMENT 2,% NM)	VIS (COUPLE 2,5 NM)	TORNILLO
R3334	*	GRANO	SCREW	DORN	GRAIN	GRANO
R3335		SPINA	PIN	SPANNSTIFT	TANON	CLAVIJA
R3340		RONDELLA POMPA HP700	WASHER	DICHTUNG	RONDELLE	ARANDELA
R3468		KIT POMPA MANUALE. +LEVA 496R				
S3008		DADO MEDIO M4 UNI 5588 ZB	NUT M4 UNI 5588 ZB	MITTLERE MUTTER M4 UNI 5588 ZB	ÉCROU M4 UNI 5588 ZB	TUERCA MEDIANA M4 UNI 5588 ZB
Z_RICAMBI		* = RICAMBI CONSIGLIATI	* = RECOMMENDED SPARE PARTS	* = EMPFOHLENE E-TEILE	* = PIECES DE RECHANGE CONSEILLEES	* = REPUESTOS ACONSEJAIOS



*Dichiarazione di conformità
Declaration of Conformity
Konformitätserklärung
Déclaration de conformité
Declaración de conformidad
EG-Conformiteitsverklaring*



WERTHER INTERNATIONAL S.p.A.
Via F. BRUNELLESCHI, 12 - 42040 CADE' (RE) - ITALY
Telefono ++/+522/9431 (r.a.) Fax ++/+522/941997

*con la presente dichiara che
déclare par la presente que
hereby declare that
erklären hiermit, daß
por la presente declara, que
verklaren hiermee, dat*

*Le traverse idrauliche - Les traverse hydrauliques -
The hydraulic jacking beam - die Hidraulischer Scherenheber*

404M - 404P



è stato costruito in conformità alle normative 98/37/CE



a été construite en conformité avec les normes 98/37/CE



was manufactured in conformity with the normes 98/37/CE



in Übereinstimmung mit den Richtlinien 98/37/CE



ha sido fabricado según las disposiciones 98/37/CE



ble produsert i samsvar med direktivene 98/37/CE

Giugno 10, 2002

Vice president Iori Werter