

Attachment 1 System Circuit Diagram

16. Exploded drawings

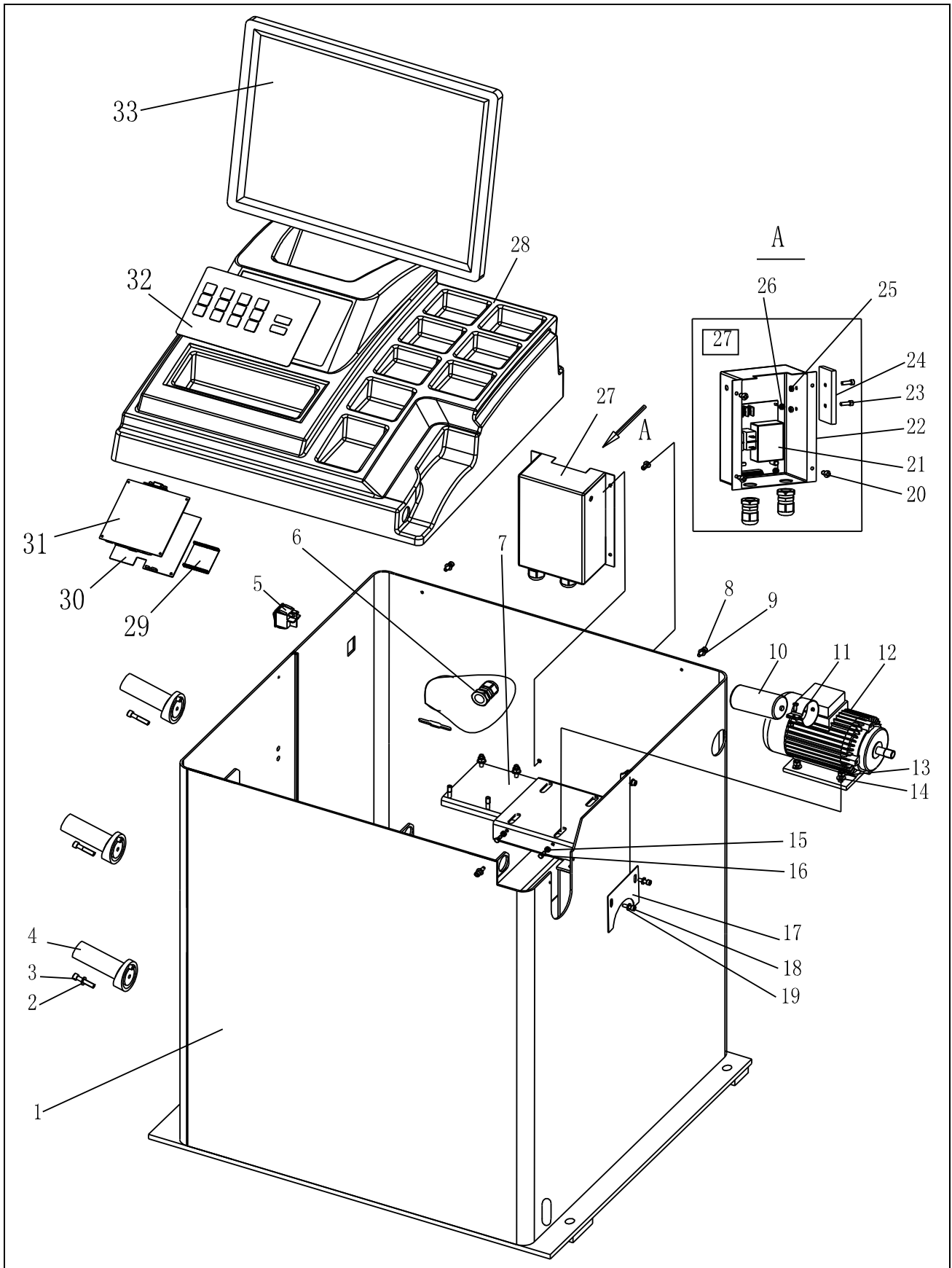

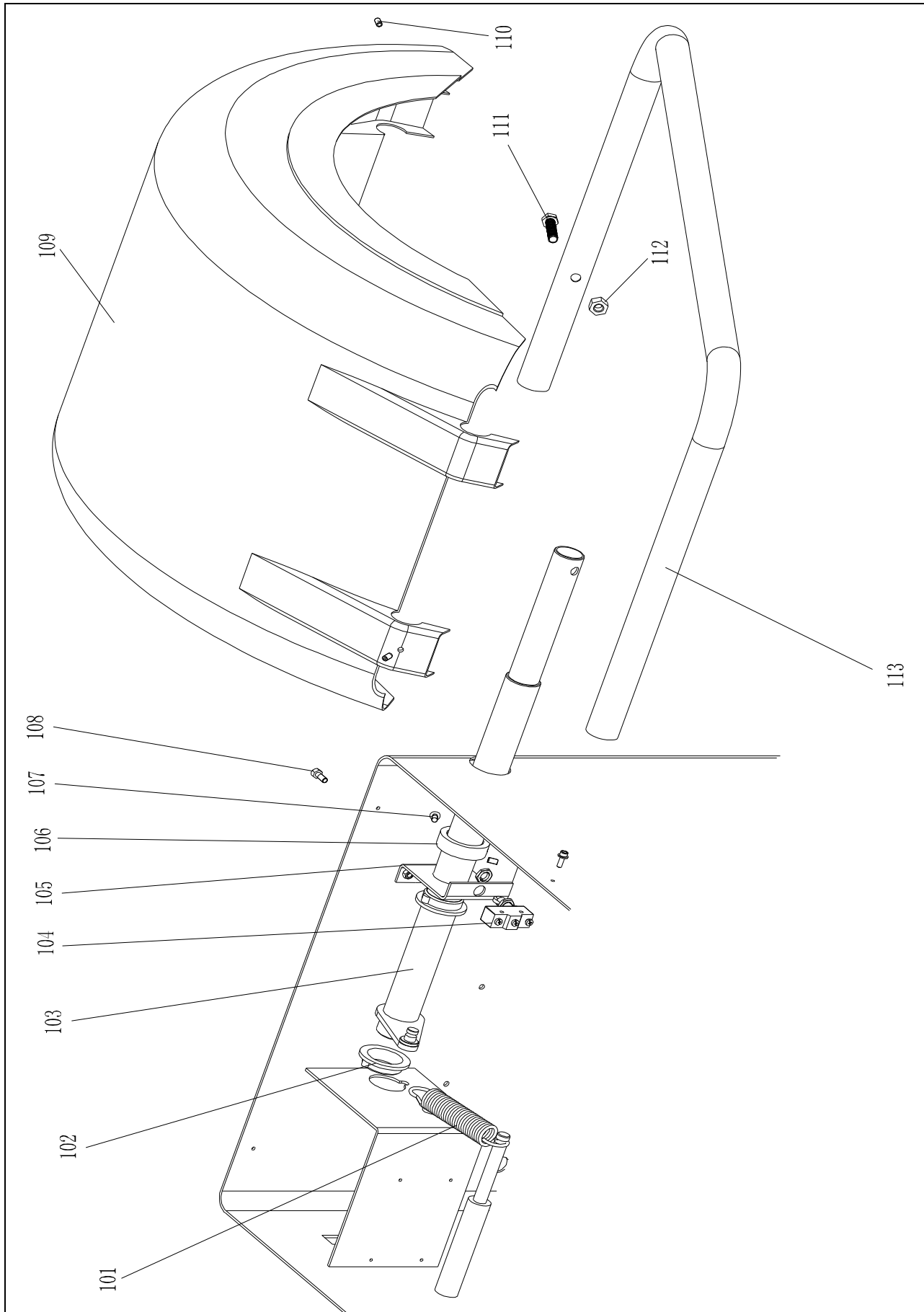

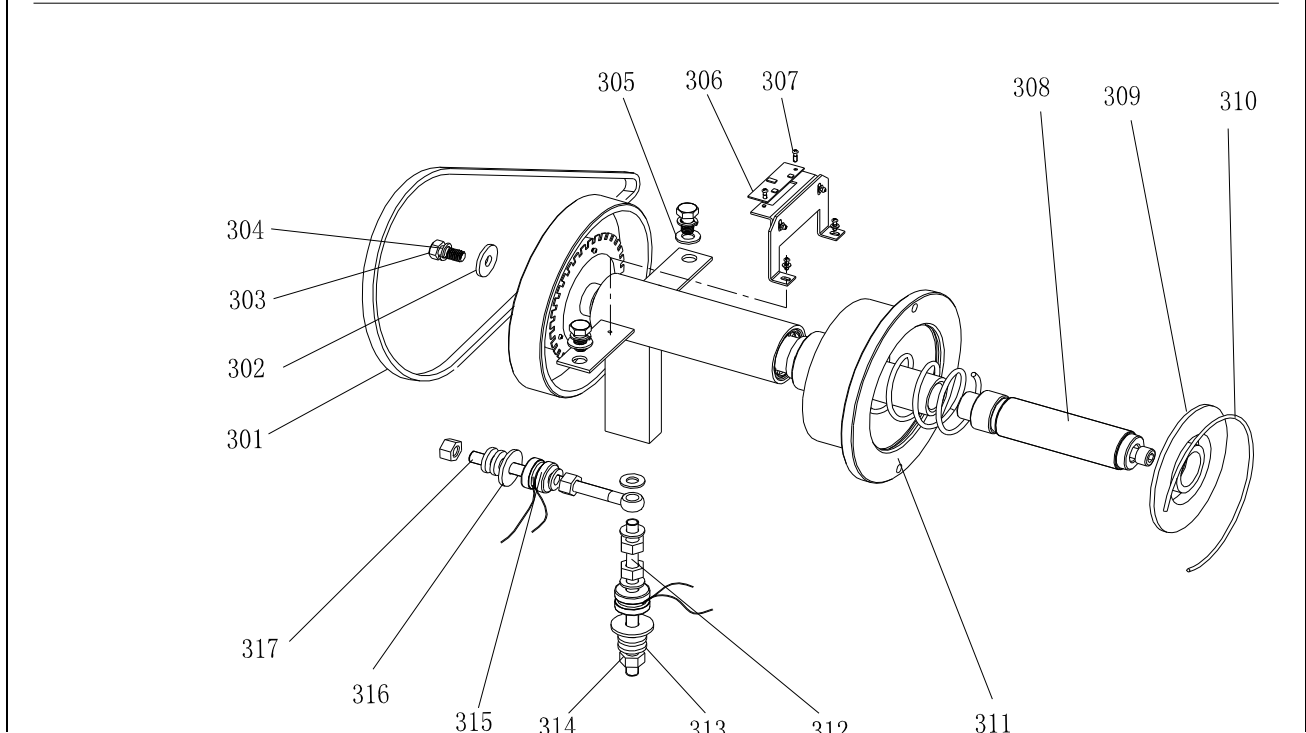
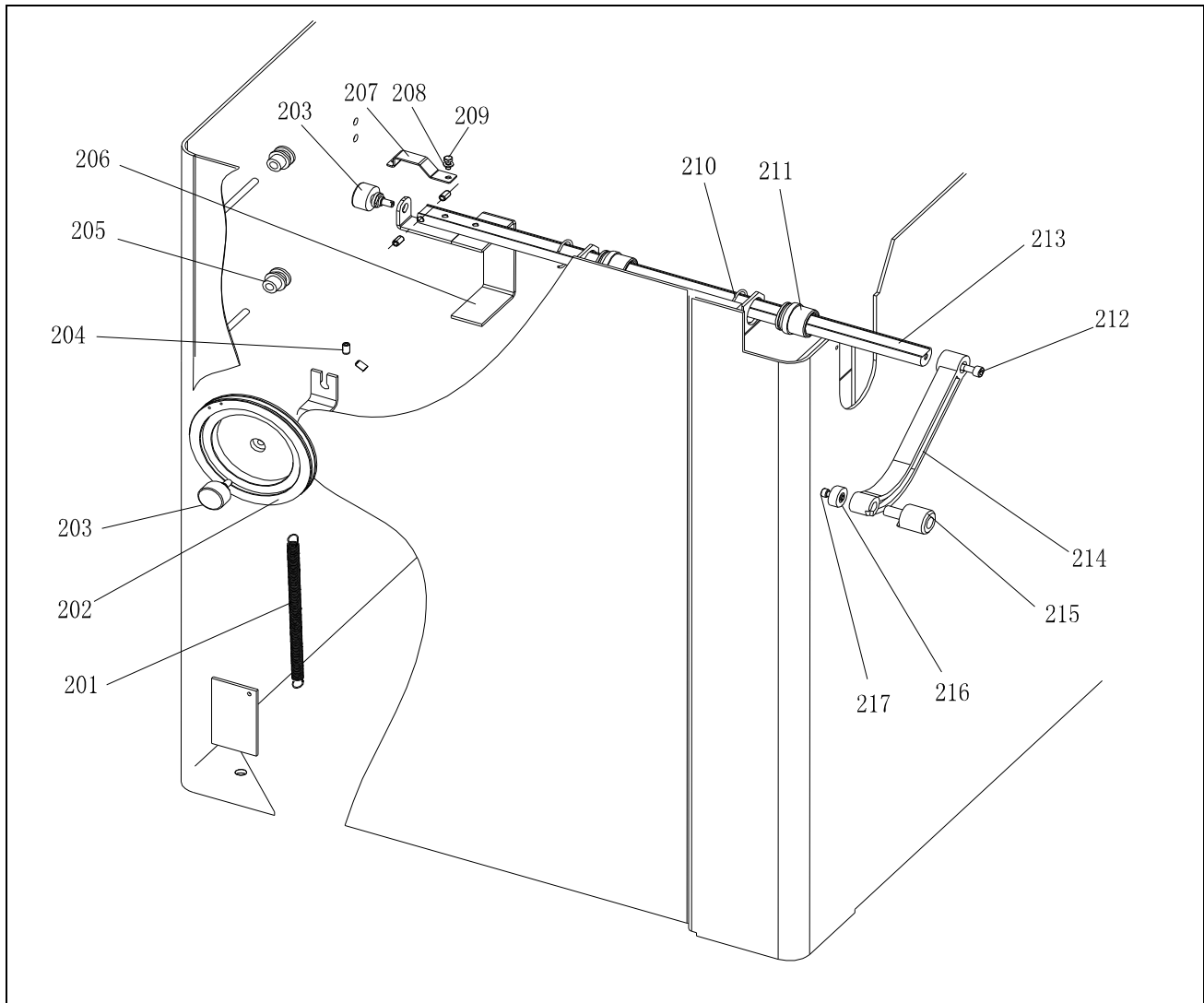

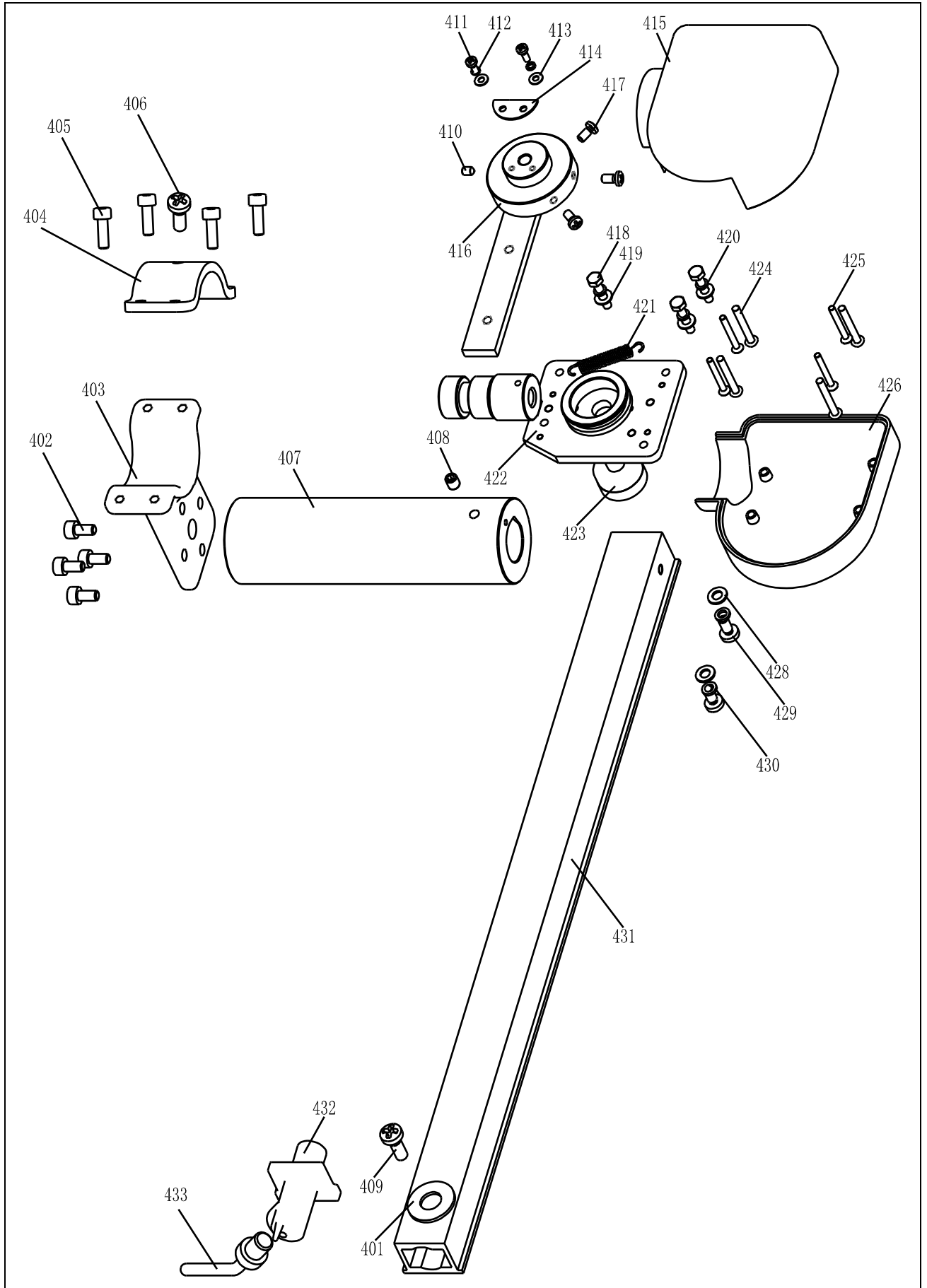

17. Spare parts list

Code	Description	Qt.	□	No.	Code	Description	Qt.
P-900-010000-0	Body	1	□	109	P-100-200100-0	Hood	1
B-040-050000-1	Washer	3	□	110	B-007-060081-0	Screw	3
B-024-050251-0	Screw	3	□	111	B-014-100451-0	Screw	1
P-000-001001-0	Tools hang	3	□	112	B-001-100001-0	Nut	1
S-060-000210-0	Power switch	1	□	113	PX-100-200200-0	Shaft	1
S-025-000135-0	Cable circlip	3	□	□	□	□	□
PX-100-010920-0	Motor adjust board	1	□	201	P-120-210000-0	Spring	1
B-024-050161-1	Screw	4	□	202	P-120-250000-0	Bobbin winder pulley	1
B-040-050000-1	Washer	4	□	203	S-132-000010-0	Gauge sensor	2
S-063-002000-0	Capacitor	1	□	204	B-007-060081-0	Screw	5
□	Hoop	1	□	205	PZ-120-260000-0	Pulley	2
S-051-230020-0	Motor	1	□	206	PX-120-240000-0	Heavy	1
B-004-060001-1	Nut	4	□	207	PX-120-230000-0	Caliper Hook	1
B-040-061412-1	Washer	4	□	208	B-040-050000-1	Washer	1
B-004-050001-1	Nut	2	□	209	B-024-050161-1	Screw	1
B-014-050351-1	Screw	2	□	210	P-100-520000-0	Seeger Ring	2
PX-100-110000-0	Plate	1	□	211	P-100-170000-0	Plastic Bush	2
B-024-050061-0	Screw	2	□	212	B-010-060161-0	Screw	1
B-040-050000-1	Washer	2	□	213	PZ-120-090000-0	Rim Distance Gauge	1
B-024-050161-1	Screw	4	□	214	P-828-160100-0	Handle Bar	1
PZ-000-020822-0	Power board	1	□	215	P-828-160800-0	Gauge head	1
PX-800-060000-0	Power board box	1	□	216	P-822-160700-0	ABS Washer	1
B-024-050251-0	Screw	2	□	217	B-010-050101-0	Screw	1
D-010-100300-1	Resistor	1	□	□	□	□	□
B-004-060001-0	Nut	2	□	301	S-042-000380-0	Belt	1
B-024-030061-0	Screw	4	□	302	B-040-103030-1	Washer	1
□	Complete power box	1	□	303	B-014-100251-0	Screw	3
P-970-190000-0	Head with tools-tray	1	□	304	B-050-100000-0	Washer	3
S-140-000030-5	CPU board	1	□	305	B-040-102020-1	Washer	6
PZ-000-010860-0	Support board	1	□	306	PZ-000-060822-0	Position Pick-up Board	1
S-140-000040-5	Show-card	1	□	307	B-024-030061-0	Screw	4
S-115-009600-0	Key board	1	□	308	□	Thread	1
S-135-001700-0	LCD	1	□	309	P-100-420000-0	Plastic Lid	1
□	□	□	□	310	P-100-340000-0	Spring	1
P-096-330000-0	Spring	1	□	311	S-100-000064-0	Complete Shaft	1
P-100-180000-0	Sheath	1	□	312	P-100-080000-0	Screw	1
PX-096-040000-0	Shaft	1	□	313	B-048-102330-1	Washer	4
S-060-000400-0	Micro switch	2	□	314	B-004-100001-2	Nut	5
PX-100-200200-0	Shaft support	1	□	315	S-131-000010-0	Sensor Assembly	2
PX-100-050000-0	Shaft sheath	1	□	316	B-040-124030-1	Washer	2
B-024-060061-0	Screw	1	□	317	P-100-070000-0	Screw	1
B-010-080201-1	Screw	2	□	□	□	□	□

No.	Code	Description	Qt.	No.	Code	Description	Qt.
401	P-870-011800-0	Magnet	1	41	P-870-010500-	Connection of arm assembly	1
402	B-010-050101-	Screw	4	41	B-024-040081-	Screw	3
403	P-870-011001-0	Installation board	1	41	B-010-040201-	Screw	3
404	P-870-011600-0	Top button up	1	41	B-040-040000-	Flat washer	3
405	B-010-050161-	Screw	4	42	B-050-040000-	Spring washer	3
406	B-024-050161-	Spring pin	1	42	P-870-010900-	Spring	1
407	P-870-010200-	Shaft cover	1	42	P-870-010100-	Revolve shaft assembly	1
408	B-007-060081-	Screw	1	42	S-132-000010-	Gauge sensor	1
409	B-019-420161-	Screw	1	42	B-024-350281-	Screw	4
410	B-007-040061-	Screw	2	42	B-017-030251-	Screw	4
411	B-024-030081-	Screw	2	42	P-870-010700-	Bottom cover	1
412	B-050-030000-	Spring washer	2	42	B-040-050000-	Flat washer	2
413	B-040-030000-	Flat washer	1	42	B-024-050101-	Screw	2
414	P-870-010600-	Fix the slice	1	43	B-050-050000-	Spring washer	2
415	P-870-010400-	Top cover	1	43	P-870-010800-	Ruler seat	

S Version Exploded drawings and spare parts list (Optional pedal brake system)

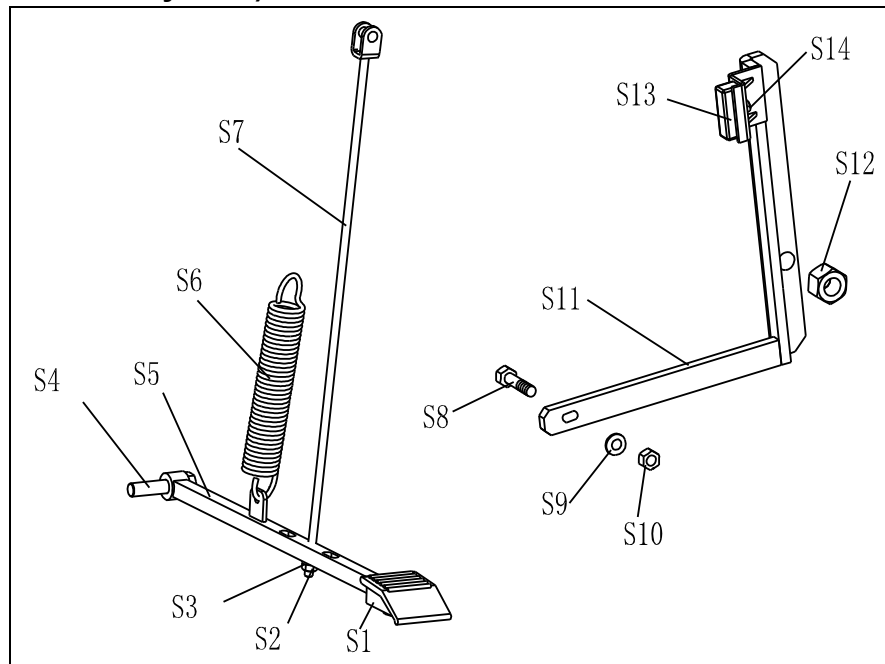

No.	Code	Description	Qt.	No.	Code	Description	Qt.
S1	C-221-640000-A	Rubber cover	1	S8	B-010-060301-0	Screw	1
S2	B-001-060001-0	Nut	1	S9	B-040-061412-1	Washer	1
S3	B-040-061412-1	Washer	1	S10	B-004-060001-1	Nut	1
S4	B-014-100251-0	Screw	1	S11	PX-100-020200-0	Brake lever	1
S5	PX-800-020300-0	Foot lever	1	S12	B-001-120001-0	Nut	1
S6	C-200-380000-0	Spring	1	S13	P-000-002001-1	Brake pads	4

S7	PX-100-020400-0	Connecting rod	1	S14	B-004-060001-1	Nut	2
----	-----------------	----------------	---	-----	----------------	-----	---

LG890990

Attached Figure 1 System Circuit Diagram

